



You can't judge a composite tank by its cover. Make sure its got **CAD-2** technology inside.

FLEX 2 PRO COMPOSITE WITH CAD-2 DIAPHRAGM.

FLEX 2 PRO composite represents the latest technology in light weight composite well tanks. Featuring Flexcon Industry's patented silver-ion-infused, antimicrobial CAD-2 diaphragm design inside, it can't be beat! If your custom-

ers are looking for the ultimate well tank, go with proven Flexcon performance and instal a state of the art FLEX 2 PRO!



Precision injection molded domes for uniform wall thickness and consistently engineered dome profiles.

High tech spin welding process permanently fuses precision injection molded domes to the extruded cylinder.

Reinforced with durable, continuous strand fiberglass and sealed from the environment with weather resistant epoxy resin. Suitable for underground installation.

SUPER SIZED
OUR LARGER TANK SIZES OFFER GREATER DRAWDOWN CAPACITY.

CAD-2

CAD-2 diaphragm technology: strong 100% butyl diaphragm and copolymer polypropylene lower water chamber for maximum water and air separation.



Every Flexcon CAD-2 tank has a silver-ion-infused antimicrobial liner to help eliminate possible water born health hazards.

Rugged base engineered to withstand maximum loads and extreme environmental conditions.

Tough, injection molded, rigid PVC connection for easy installation and lifetime performance.

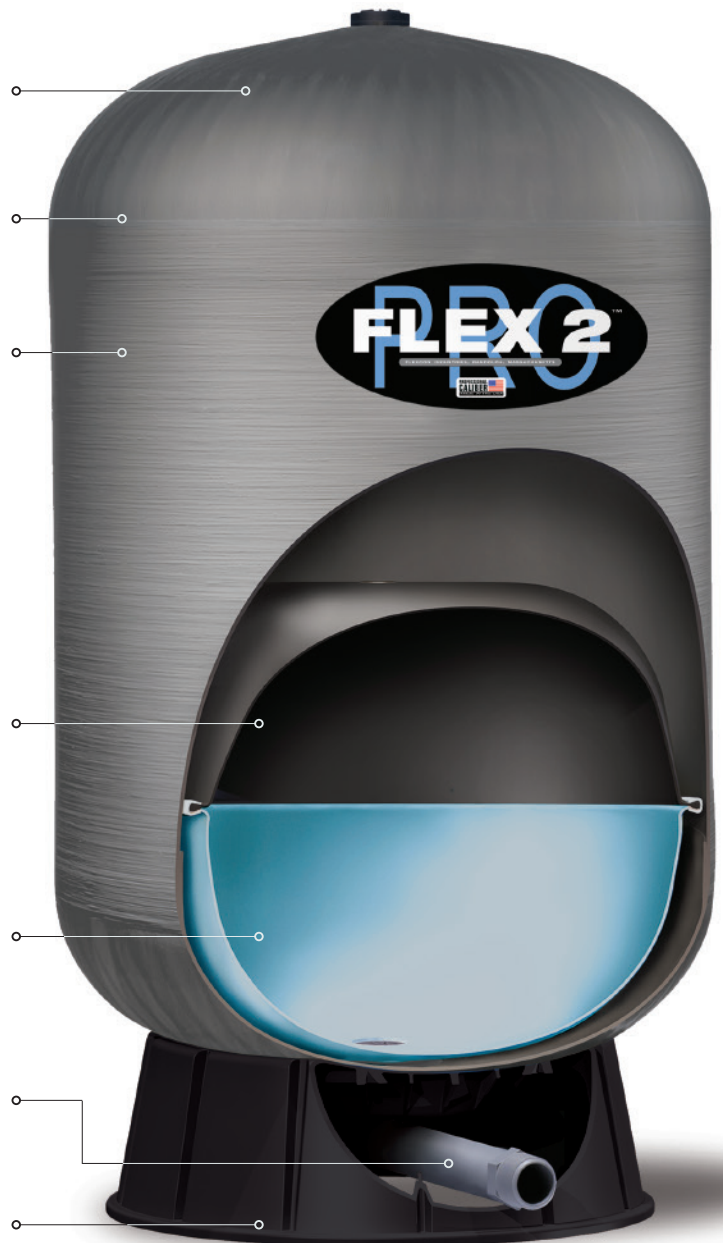



H2PL SERIES

Composite

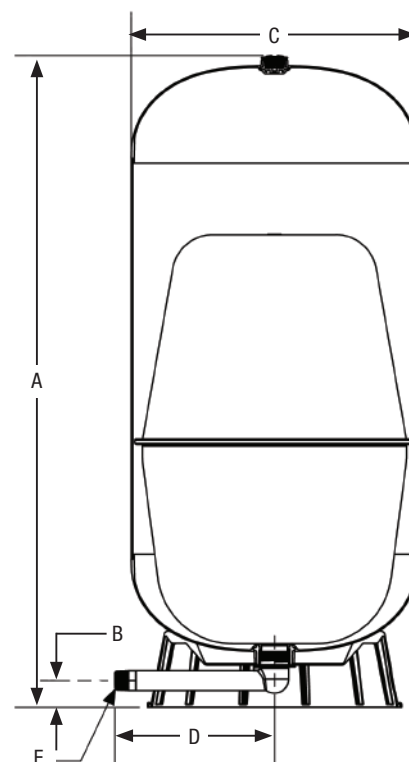

MATERIALS OF CONSTRUCTION

- **Top and bottom domes:** Injection molded copolymer polypropylene
- **Shell:** Extruded copolymer polypropylene
- **Outer shell:** Fiberglass-wound, coated with epoxy resin
- **Water chambers:** Top diaphragm is 100% butyl rubber, lower water chamber is anti-microbial, copolymer polypropylene
- **Base:** Copolymer polypropylene
- **Connection:** Rigid Schedule 80 PVC
- **Air valve:** Easy to access brass valve with o-ring seal
- **Testing:** High pressure, seam weld, helium, final precharge check
- **Warranty:** 5 year limited

COMPOSITE TANK DIMENSIONS

Model	Total Tank Volume		A Height		B Floor to CL		C Diameter		D CL to fitting end		E Connection	Total Weight	
	gal	liters	in	cm	in	cm	in	cm	in	cm		lbs	kilos
H2PL 15	15	56.8	25.60	64.0	1.75	4.4	16.5	41.9	9.4	23.9	1" NPT	19.0	8.6
H2PL 22	22	83.3	34.10	84.1	1.75	4.4	16.5	41.9	9.4	23.9	1" NPT	24.0	10.9
H2PL 35	35	132.5	48.90	121.7	1.75	4.4	16.5	41.9	9.4	23.9	1" NPT	33.5	15.2
H2PL 38SQ	38	143.8	29.75	74.7	2.25	5.7	24.2	61.5	11.9	30.2	1 1/4" sch 80	35.0	15.9
H2PL 50	50	189.3	43.30	109.0	2.25	5.7	21.4	54.4	11.9	30.2	1 1/4" NPT	47.0	21.3
H2PL 65	65	246.0	51.30	129.3	2.25	5.7	21.4	54.4	11.9	30.2	1 1/4" NPT	58.0	26.3
H2PL 82	82	310.4	64.70	163.3	2.25	5.7	21.4	54.4	11.9	30.2	1 1/4" NPT	69.5	31.5
H2PL 90	90	340.7	57.00	143.8	2.25	5.7	24.2	61.5	13.4	34.0	1 1/4" NPT	77.0	34.9
H2PL 120	119	450.4	72.10	182.1	2.25	5.7	24.2	61.5	13.4	34.0	1 1/4" NPT	99.5	45.1

Maximum working pressure 125 psig. Maximum working temperature, internal & external 120° F. Tank pre-charge 38 psig.

QUICK SIZING CHART

Model	Total Tank Volume		Total Drawdown*					
	gal	liters	20/40		30/50		40/60	
	gal	liters	gal	liters	gal	liters	gal	liters
H2PL 15	15	56.8	6.00	24.1	5.1	20.4	4.4	17.7
H2PL 22	22	83.3	8.80	32.2	7.5	27.2	6.5	23.6
H2PL 35	35	132.5	14.10	52.3	11.9	44.2	10.3	38.3
H2PL 38SQ	38	143.8	13.89	51.8	11.8	44.0	10.5	39.4
H2PL 50	50	189.3	20.10	76.4	17.0	64.6	14.7	56.0
H2PL 65	65	246.0	26.10	100.5	22.1	85.0	19.1	73.6
H2PL 82	82	310.4	33.00	120.7	27.9	102.0	24.1	88.4
H2PL 90	90	340.7	36.20	136.7	30.6	115.6	26.5	100.1
H2PL 120	119	450.4	47.90	181.0	40.5	153.0	35.0	132.5

*Total drawdown assumes tank pre-charge set at 2 psi below cut-in pressure. Drawdown can be affected by many factors, including temperature, pressure, and elevation.

